

# Work-In: Final Report

20 November 2020

ME 386W

Team 1

Garrett Cornelius

Martín Dorantes

Daniel Castano

Preston Berchtold



Northern Arizona University

## **Table of Contents**

<i>Executive Summary</i> .....	<b>3</b>
<i>Introduction</i> .....	<b>4</b>
<i>Problem Definition</i> .....	<b>4</b>
<i>State-of-the-Art and Literature Review</i> .....	<b>5</b>
<i>Concept Generation &amp; Selection</i> .....	<b>5</b>
<i>Engineering Analysis</i> .....	<b>8</b>
<i>Cost Analysis</i> .....	<b>13</b>
<i>Ethical Standards</i> .....	<b>15</b>
<i>Conclusion</i> .....	<b>16</b>
<i>Appendix A – QFD</i> .....	<b>17</b>
<i>Appendix B – Morph Matrix</i> .....	<b>18</b>
<i>Appendix C – Concepts</i> .....	<b>19</b>
<i>Appendix D – Pugh Chart</i> .....	<b>22</b>
<i>Appendix E – Decision Matrix</i> .....	<b>23</b>
<i>Appendix F – Programming</i> .....	<b>24</b>
<i>Appendix G – Fastener Tables</i> .....	<b>25</b>
<i>Appendix H – Time Value of Money</i> .....	<b>26</b>
<i>References</i> .....	<b>27</b>

## **Executive Summary**

This document showcases how the evolution of workout equipment and exercise with the continuing COVID-19 pandemic. This project serves anyone impacted by the coronavirus from gym closures. Team 1 set their goal to create an interactive, motivational, and compact device that combines both cardiovascular and muscle training exercises. The client and stakeholder, Dr. Moghaddam, assisted in specifying requirements for the completion of this project. Hospitals may benefit from the production of this product for physical therapy uses. To tackle this task, the team needed to identify all necessary requirements from analyzing the problem statement. Team 1 identified all objectives & constraints, customer needs, and engineering requirements to create a Quality Function Deployment. The design process carried to funnel down to the final design, the Body Pal. After the chosen design was the steps to Engineering and Cost Analysis. Important key features to note are minimized volume of the device, muscle training, cardiovascular training, and motivational for the user to exercise as well as inclusion of wireless motion-tracking software. The design for the Body Pal holds appealing profit margin and return on investment from a business standpoint.

## **Introduction**

With the COVID – 19 Pandemic continuing for now almost 1 year, the effects on the worldwide economy as a whole have been disastrous. In the United States specifically, there are many states that have attempted to initiate stay at home orders and have mandated that all gathering places either close entirely or uphold extreme counteractive measures such as social distancing and face coving mandates. These actions have laid waste to the local gym industry. Many gyms have closed entirely or have had to reduce their capacity to meet the state guidelines. This major shutdown impacts not only the employees and personal trainers that work for the gym, but those who attend the gym on a regular basis. For many Americans, the gym is an essential part of their daily routine, some use it as a place to meditate and others use it to maintain or increase their level of physical fitness. Without the local gyms, there is an increasing need for a device that the average American would be able to achieve the necessary levels of strength and cardio training. There is a growing need in the market for a device that is simple, affordable, safe, and effective that people can use in the safety and convenience of their own homes.

## **Problem Definition**

The COVID-19 pandemic has created shifts in safety standards and expectations. To help combat the virus, peoples are isolating and quarantining from others to help the spread of the virus. Therefore, daily routines of going to a gym and getting in a physical exercise has been limited or stopped entirely.

### **a. Goal**

Team 1's mission goal was to design an interactive and compact in-home exercise device. The device would provide the same gym workout at home through cardiovascular training, strength training, and meditation activities. The device is to provide motivational activities for all age ranges, while also ensuring safety among all users.

### **b. Stakeholders**

The primary stakeholder of the Work-In design is our client, Hesam Moghaddam. Hesam has overlooked the project while providing different objectives and constraints to ensure the device meets the needs. Other stakeholders involved are fitness enthusiasts. With the COVID-19 virus shutting down all public and private gyms, fitness enthusiasts are looking for new alternatives to continue their healthy lifestyle. Therefore, Team 1 believes the Work-In design would best suit fitness enthusiasts needs and help them continue their healthy lifestyle.

### **c. Objectives and Constraints**

To start, the primary constraint for the Work-In device is to incorporate electromechanical components into the design. To follow, the Work-In design also needs to be condensed and compact to fit easily in a small apartment. For objectives, the device needs to be able to perform cardiovascular and strength training from within the home. The device should also be able to uphold a fitness routine for any age (intended ages 12-60). Another objective is for the device to motivate users and ensure they continue to use the product for at-home fitness needs. Lastly, the device should prioritize safety above all other functions and ensure that users cannot be injured or hurt from the device in any way.

## State-of-the-Art and Literature Review

The State-of-the-Art (SOTA) is a research technique used by engineers to understand the most relevant and up-to-date designs on the market. SOTA research involves researching patents, handbooks, and journal articles relevant within the last 5-10 years to provide the most up-to-date information. Within the research, Team 1 found several devices that could be of use to the semesters design. The most useful patents, handbooks, or articles were outlined in Table 1.

Table 1: Literature Review

Literature	Type	Summary/Impact
<i>Unconstrained Workout Activity Recognition on Unmodified Commercial off-the-shelf Smartphones</i>	Journal Article	Establishes use of cell phones and their sensors to help correct and give feedback on fitness
<i>Standard Specification for Fitness Equipment</i>	Handbook	Outlines terms for manufacturing and specifying fitness equipment
<i>Feedback Device for Guiding and Supervising Physical Exercise</i>	Patent	Outlines a patent for using a mirror type device for fitness use
<i>The Science and Development of Muscle Hypertrophy</i>	Book	Identifies muscle compound groupings and how to enhance strength
<i>Most Americans plan to continue at-home workouts even once gyms fully reopen</i>	News Article	News impacting COVID-19 and gym usage, states most people will stay home to work out

From the literature review, we discovered a few trends that would help with Team 1's design. To start the news article, outlines that the trend of no longer going to a gym is prevalent and will continue into the foreseeable future. Therefore, our device is needed and will continue to be needed for the future. To follow, the handbook will help guide the team in design choices through standards set by ASTM. To create a device that would ensure formal training, the book *The Science and Development of Muscle Hypertrophy*, would help Team 1 create workouts that meet cardiovascular and strength training requirements. Lastly, the literature review helped discover alternatives for sensing and correcting fitness training through cell phones.

## Concept Generation & Selection

As outlined within the ME 386W course, the design process was followed thoroughly as a real-world design process would follow. Team 1 started with benchmarking existing products on the market, to generating concepts based on customer needs, engineering requirements, and project objectives, to funneling the generated concepts into a Pugh Chart and Decision Matrix to find the final design. All process steps are outlined below in detail.

### a. Benchmarking

At the beginning of any design process, teams must complete benchmarking research to ensure originality is used for the device being worked on. With this project, there is a large market for at-home fitness surrounding the COVID-19 pandemic. In the case for Team 1, the following devices were used as a benchmark datum.



**Figure 1 - Pelton Bike [1]**

The Pelton Bike from Figure 1 is used as a datum due to its combination of cardiovascular and muscle training capabilities with multiple mode settings. A notable drawback of the Pelton Bike is that it requires a subscription for use. This upsell is a marketing tactic to increase profit margins from a business perspective. The device does not incorporate a compact design or a motivational interface, depending on the subscription purchased.



**Figure 2 - The Mirror [2]**

The Mirror shown in Figure 2 is considered a technology breakthrough. This design incorporates a motivational interface and compact design but fails to meet the proper muscle training requirements. One drawback of The Mirror is the price, set at about \$1,500. The high price creates a threshold for users who cannot afford this piece of equipment. While the device has many exercising capabilities, there are many people who cannot benefit from the device because of the price for larger profit margins.



**Figure 3 - BoFlex [3]**

The BoFlex shown in Figure 3 is very well known nowadays. Key features include proper muscle training, but lack motivational features, cardiovascular training, and a compact design. This device is affordable for the average household, however the profits gained come from the marketing BoFlex does as a company. Most Americans know what the BoFlex is due to the commercials seen from TV, leading to higher interest and conversion rates that generate more business.

These figures compare customer needs to what exists in-stores today. These datums are used to establish a starting point for concept generation.

**b. Concept Generation**

Team 1 took all datum points into consideration when generating concepts that fulfill all sub-functions. Team 1 used the 6-3-5 method and a bio-inspired variant when generating possible device concepts. The tabulated concept variants are shown in Figure B.1 of Appendix B in the Morph Matrix.

Each concept generation is shown in Appendix C, through Figures C.1-C.6. These six concepts were evaluated based on their design criteria and entered into a Pugh Chart for further analysis.

**c. Pugh Chart**

The Pugh Chart is shown in Figure D.1 of Appendix D and weights the ranking of each sub-function based on the concept variant. Each of the six variants were ranked as a team, where the three lowest ranking variants were removed from the design process and the highest ranking variants were moved onto the final Decision Matrix.

**d. Decision Matrix E.1**

Upon completion of the Pugh Chart, Team 1 inputted the top three concept generations into the Decision Matrix, seen in Figure E.1 of Appendix E. The Decision Matrix ranks the top three scoring concepts from the Pugh Chart based on the project objectives and constraints. Each criterion carries a weighted influence on the importance of each

objective. Each concept was ranked and weighted to guide Team 1 to the final design concept, the Body Pal.

## Engineering Analysis

### a. Coding analysis

The Body Pal program was written using Python 3.8. All figures are from the running program.

As a team of students, we were limited on programming language knowledge to complete all aspects of a digital display app. App interfaces require long periods of testing and debugging before a program is approved. The concepts driving the interface are simplicity and compressed. A complicated system yields complicated issues; however, the simplest programs require long testing periods. The Kaltura Capture tool in BBLearn was most useful in visually showing the code and the flow of the interface as a user would experience.

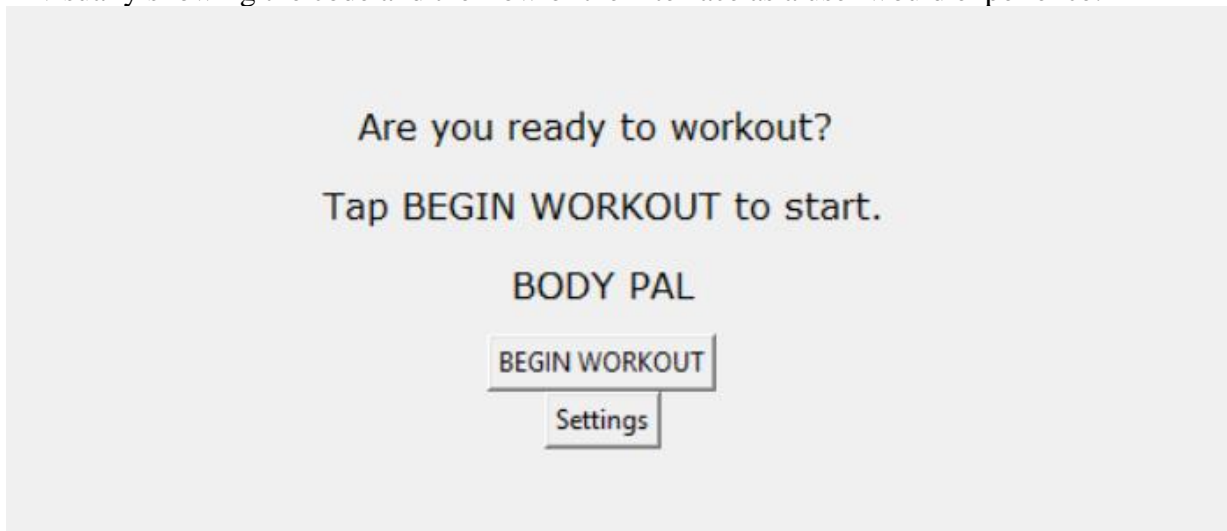

**Figure 4 – Code Welcome**

The interface shown in Figure 4 keeps simplicity by giving two options only: workout or configure settings. Psychologically, this is a form of motivation because with two options, exercising has the highest chance of being selected by 50%.





**Figure 5 – Device Profiles**

Personalized profiles, seen in Figure 5, are for keeping track of all family members.

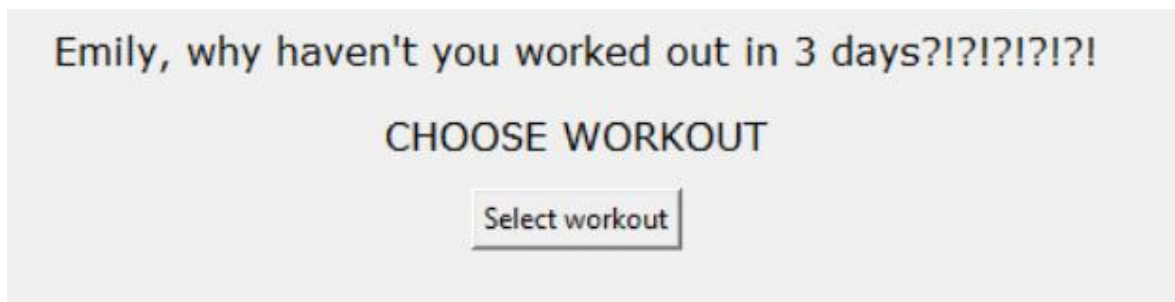

**Figure 6 – Motivation in software**

In this testing case from Figure 6, the device tracks and displays the last time the user exercised. Displaying the period between workouts adds a motivation factor to keep this number as low as possible. It adds reminders of missed days to incentivize the user to log in. Again, leaving only one option on this display promotes the path to complete an exercise. The only way back is forward with this program. Leaving one option prompts the user to fully commit to working out.

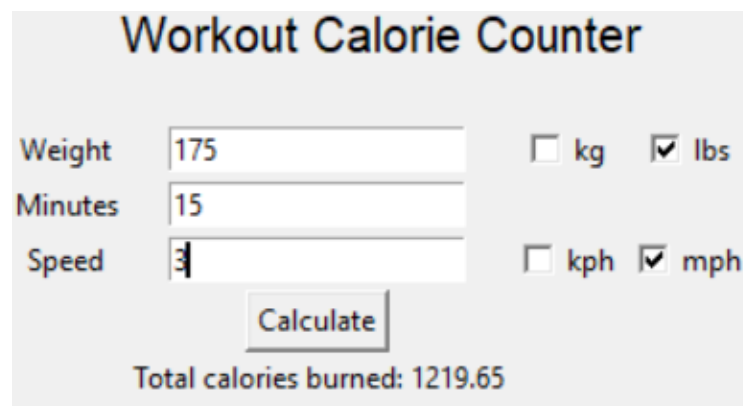

## Figure 7 – Calorie Tracker

The workout calorie counter in Figure 7 shows how the interface would complete after a workout, this page specific to calories burned from the selected workout. To promote international sales, the device has unit configurations to gain more sales across multiple countries. This automatically follows up the workout and can be used to calculate an approximate calorie calculation to estimate a future workout burned calories. If the device were to follow through with production, the program would need months of time to properly test and configure all features needed for the ideal market device.

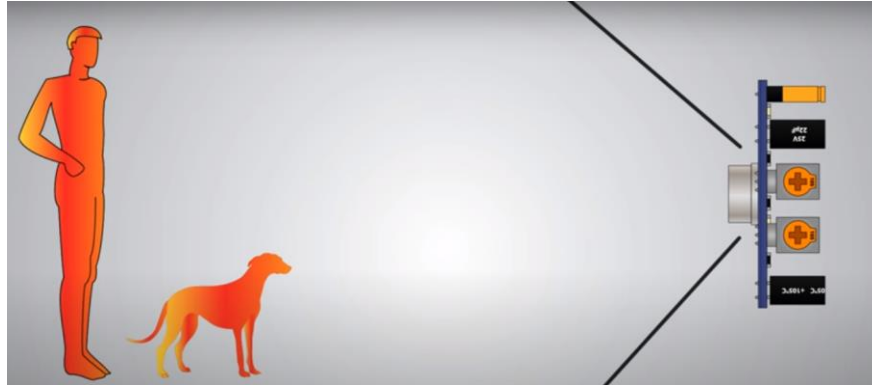

**Figure 8 - Passive Infra-Red (PIR) sensor**

The motion-tracking sensor would be a PIR sensor. PIR detects only motion of figures emitting heat. The pickup of the sensor is shown in Figure 8, however with the combination of the motion-tracking bands, the PIR sensor would only pick up motion from the body between the bands. Someone walking by or a pet would not disrupt the motion feedback from the sensor. A noteworthy feature of using a PIR sensor is that it does not use any energy itself, an added benefit to energy conservation.

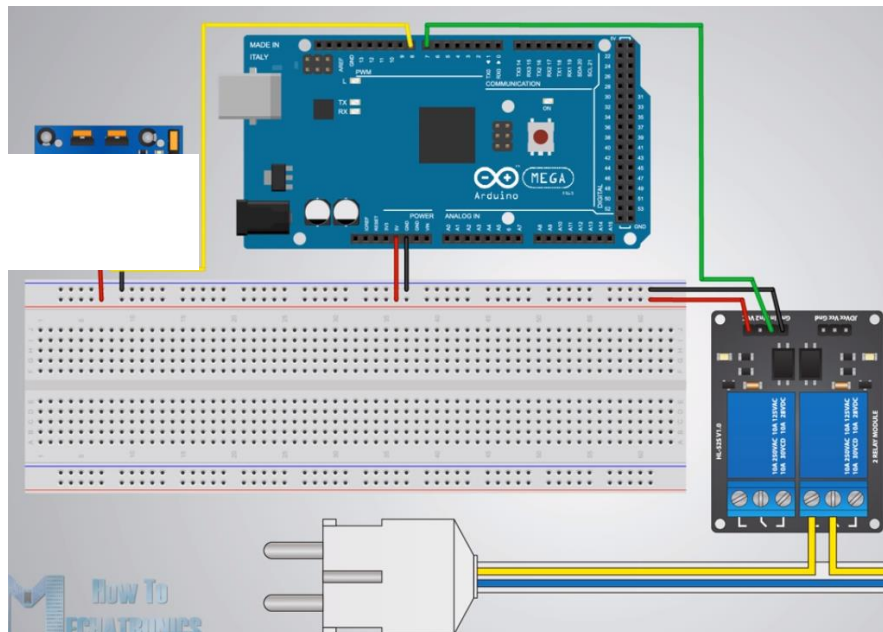

## Figure 9 - Arduino Configuration

Figure 9 shows an actual Arduino configuration connection to a PIR sensor. The breadboard, dupont wires, and Arduino MEGA are all key elements in the compatibility of the Body Pal.

### b. Weighted Gloves

The process of this analysis involves first establishing a reasonable value for an individual's systolic blood pressure. The systolic blood pressure is the force the blood exerts on the walls of blood vessels after each heart beat [5]; any radial force exerted on a limb that exceeds the systolic blood pressure prevents blood flow [7]. The wrist strap will be made of an elastic material capable of stretching. To analyze the force generated by it, the calculations will implement Hooke's Law. Hooke's law typically describes springs but can be applied to elastic materials so long as the material does not stretch past its elastic limit [6].

Six assumptions are to be made to perform these calculations. First, assuming that the material used for the wrist strap is Seals Eastern 7282 Neoprene, the modulus of elasticity would be 6.14 MPa [4]. Second, it is assumed that the force applied by the strap is uniform around the wrist and normal to the surface of wrist, which will be modeled as a cylinder. Third, it is assumed that the change in length will be represented by the change in diameter of the strap when it is on the wrist versus off. Fourth, it is assumed that the wrist in question has a width of six centimeters. Fifth, the wrist strap is assumed to have the width of 0.02 m and a thickness of 0.0005 m. Lastly, it is assumed that the user has a common systolic blood pressure of 120 mm Hg, or 0.01598 MPa.

The process for calculating the pressure applied by the strap is as follows:

- Known
  - $P_b = \text{systolic pressure} = 0.01598 \text{ MPa}$
  - $L_o = \text{initial length} = 0.04 \text{ m}$
  - $L = \text{stretched length} = 0.06 \text{ m}$
  - $t = \text{thickness} = 0.0005 \text{ m}$
  - $E = \text{modulus of elasticity} = 6.14 \text{ Mpa}$
  -
- Unknown
  - $P_a = \text{pressure on arm} = ?$
- Hooke's Law:
  - $F_a = k\Delta L = E\left(\frac{A_c}{L_o}\right) \Delta L = E\left(\frac{2Lw}{L_o}\right) \Delta L \quad (1)$
  - Plugging into equation (1)
    - $F_a = 6.13 * 10^6 \text{ Pa} * \left(\frac{2*0.0005 \text{ m} * 0.02 \text{ m}}{0.04 \text{ m}}\right) * 0.01 \text{ m}$
    - $F_a = 30.65 \text{ N}$
- Pascal's Law:
  - $P_a = \frac{F_a}{A} = \frac{F_a}{\pi Lw} \quad (2)$
  - Plugging into equation (2)

- $P_a = \frac{30.65 N}{\pi * 0.06 m * 0.02 m} = 8130.2 Pa$
- $P_a = 0.0081302 MPa$

○ Results:

- $P_a < P_b$
- $0.0081302 MPa < 0.01598 MPa$ , therefore the wrist strap will not cut off circulation

### c. Screw and Fastener

The team next analyzed fasteners and screws to ensure the device would stay secured to the wall. The analysis process can be done in several ways, but this analysis chose the fasteners to be determined first and then tested to evaluate the FOS of safety involved. The evaluation of fasteners is also not very straight forward and requires several “look-up” tables and inequalities to evaluate the fastener will meet stiffness criteria and thread strength.

To start, Team 1 decided to use a #10–32 3½ in. UNC-SAE 1 fastener. The threads per inch, pitch, major and minor diameter, and tensile-stress area are all given in Appendix G.1 and G.2 [12]. The fastener is now examined for stiffness through means of evaluating grip, length (threaded and unthreaded), and area (threaded and unthreaded) to help evaluate the safety involved. Figure 10 outlines a better understanding of what each variable is [12].

- Grip Length

$$l = \begin{cases} h + t_2/2, & t_2 < d \\ h + d/2, & t_2 \geq d \end{cases} \quad (3)$$

- Fastener Length

$$L > h + 1.5d \quad (4)$$

- Threaded Length

$$L_T = \begin{cases} 2d + \frac{1}{4} in, & L \leq 6in \\ 2d + \frac{1}{2} in, & L > 6in \end{cases} \quad (5)$$

- Length of unthreaded and threaded portion in grip

$$l_d = L - L_T \quad \& \quad l_t = L - l_d \quad (6 \ \& \ 7)$$

- Area of unthreaded portion

$$A_d = \frac{\pi d^2}{4} \quad (8)$$

- Bolt Stiffness

$$k_b = \frac{A_d A_t E}{A_d l_t + A_t l_d} \quad (9)$$

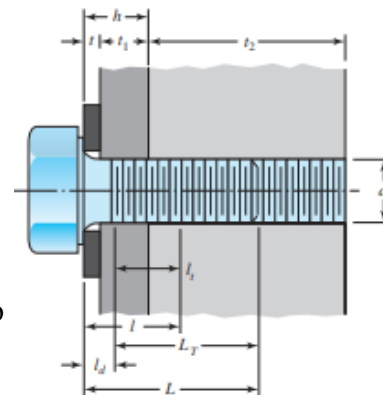

Figure 10 - Fastener Variables [12]

After evaluating stiffness of the bolt, Table G.3 can be referred to understand the fastener’s proof strength, yield strength, and tensile strength. From here calculations of the factors of safety (FOS) for load and yield can be determined [12].

- Yield FOS

*Variables used in Eqn (10 & 11)*

$$n_p = \frac{S_p}{CP+F_i} \quad (10)$$

- Load FOS

$$n_L = \frac{S_p A_t - F_i}{CP} \quad (11)$$

$F_i = \text{PreLoad (if any)}$

$S_p = \text{Proof Strength}$

$C = \text{Bolt Stiffness}$

$P = \text{Max Load on Bolt}$

Using an excel sheet helped expedite the long process for testing several bolts. Our excel calculations determined a Yield FOS of 1.301 and a Load FOS of 13.586 .

#### d. Calorie Loss Analysis

Lastly, Team 1 analyzed a method for counting calories for The Body Pal. Typically within an industrial fitness machine, a method or tracker of calories lost is shown to motivate the user and track their progress. To develop this sub-function with the team's design, an analysis was performed of how industrial fitness machine track and relate this information to the user.

The Metabolic Equivalents system (METs) was developed to give a more accurate account of energy used during a physical activity. The system is based off the average energy used by a user sitting still and doing nothing physically active. This average is then compared to a METs value that ASU and National Cancer Institute have compiled in a compendium of physical activities [10].

$$\text{Calories Burned} = \frac{3.5W(\text{METs})}{441} * t \quad (12)$$

In Eqn (#):

$W = \text{Weight (lbs)}$

$\text{METs} = \text{Metabolic Equivalent}$

$t = \text{time of Physical Activity}$

Table [2] : Example MET Values

Activity	METs Score
Jogging in Place	8.0
Jumping Jacks	6.0
Squats	5.0

To note, the accuracy of counting calories in this method can be slightly inaccurate and skewed due to the user's health, metabolic rate, and age. But this method is also the most used among fitness equipment and calorie calculator.

### Cost Analysis

#### a. Life Cycle Cost

The Purpose of the Life-Cycle Cost (LCC) analysis is to determine the cost of owning the Work-In device. This analysis will take into consideration the initial purchase price (including taxes), installation, monthly subscription, warranty, spare parts, and cost of electricity. The general form of the governing equation used to calculate the total cost of ownership is as follows:

$$C_T = n_p \left( S_p + C_x + C_w + C_{sp} + t_m(C_s) + t_m(C_E) \right) \quad (13)$$

In which  $C_T$  represents the total cost of ownership,  $n_p$  is the number of units,  $S_p$  is price per unit,  $C_x$  is product sales tax,  $C_w$  is the cost of warranty per unit,  $C_{sp}$  is the cost of spare parts per np units,  $t_m$  is the time in months that the user has had a subscription to

the workout guides,  $C_s$  is the cost per month of the subscription, and  $C_E$  is the cost per month of the required electricity. As we have not yet created a prototype of the Work-In, the starting price and the price for spare parts is still yet to be determined, however, we can still make approximations to evaluate a reasonable LCC value. For the purposes of this calculation, our starting price will be \$600 (which is a reasonable value based on prices of existing devices as well as for the quality we intend on providing) with a spare part cost of \$50 per unit. It is assumed that the power,  $P$ , drawn for the Work-In is comparable to that of a high definition television, approximately 234 Watts [5], and that it is operating in Arizona where it costs 12.8 cents per kilowatt-hour [4] of electricity. This would equate to costing \$1.797 per month,  $C_E$ .

The LCC calculation is as follows:

- Variables
  - $C_T = ?$
  - $n_p = 1 \text{ unit}$
  - $S_p = \$600$
  - $C_x = S_p * 0.056 = \$33.6$
  - $C_w = \$30$
  - $C_{sp} = \$50$
  - $t_m = 24 \text{ months}$
  - $C_s = \frac{\$5}{\text{month}}$
  - $C_E = \frac{\$1.797}{\text{month}}$
- Plugging into equation (13)
  - $C_T = 1 \text{ unit} \left( \$600 + \$33.6 + \$30 + \$50 + 24 \text{ months} \left( \frac{\$5}{\text{month}} \right) + 24 \text{ months} \left( \frac{\$1.797}{\text{month}} \right) \right)$
  - $C_T = \$876.73$

As seen by the above calculation, it would cost the theoretical user \$876.73 to own the product.

## b. Value Analysis

**Table 3 - Value Analysis Table**

Function	Part	% of Part Cost for Function	Part Cost, \$	Function Cost of Individual Part, \$	Total Cost, \$
Successful Program	Digital Mirror	100	125	125	197
	Power Band connection	100	17	17	
	Motion sensor	100	55	55	
Weighted resistance	Glove	50	34	17	17
Mirror support	Drill holes	70	12	8.4	8.4
Increase life	O-rings	20	15	3	65.5
	Housing	50	125	62.5	
Transfer electric energy	Outlet connection	100	55	55	55

With an estimated cost of manufacturing of \$411.81, the target market price is set at \$600.00. Our set profit margins are still less than those compared to any of Team 1's benchmark datums, however from a business standpoint, this is a possible lead to generate more sales with a cheaper market price that combines more functional abilities than other existing devices. Table 3 breaks down the functionality of each part and the components of each function. Percentage of cost per function and function cost of each part were analyzed and tabulated for the total value analysis.

### **c. Time Value of Money**

A valuable concept in a product's development is research into the design's economic factors and impacts. This requires an analysis on the perspective customers, marketplace, economy, and even financing of the project. The goal of this research is to predict the costs of the design aspects. When a group requires outside funding, the lender requires these costs to evaluate what their return will be and if the project is worth funding. It is important to note that funding must be committed in advance of being paid for the service or product. In terms of this specific analysis, the calculation will determine the value of the money invested into the process with the addition of the value that has been added over time. For this project, the formula for computing time value of money considers the payment now, the future value, the interest rate, and the time frame. For this project, the start-up capital will need to be borrowed from a lender. In order to do so, the lender would most likely need to see an explanation or reasoning for the value that you wish to borrow. [13]

Below in Appendix H, there is a line item cost assumption chart for a two-year development cycle. Using the total of these values as well as a 15 percent additional buffer, the total cost that would need to be borrowed is \$811,440. Using a 3.5 percent yearly compounded interest rate, and the equation in Appendix H (Eqn. 14), the value of the company would be shown to be approximately \$868,240.80. While this value is sizeable, it is important to note that the average revenue from Anytime Fitness, a staple in the local gym industry, is over 1 billion annually. This makes the Work-In team a low budget start-up in this sector with much room to grow in an expanding market.

### **Ethical Standards**

In any engineering endeavor, there are always ethical dilemmas involved. Team 1 faced ethical dilemmas regarding user privacy and safety of truthful information, based on the National Society of Professional Engineers [4]. One ethical dilemma comes from the information provided to the user. The user should be given the truthful information of what their workouts do for them regarding calories burned, time of exercise, goal progression, etc. Without truthful information to the user, the Body Pal would be in direct violation of point I. Fundamental Canons. Another dilemma Team 1 faced was also with the program. The Body Pal is not to collect the user's private data. The user should feel comfortable with using the device. Breaching the user's private data is a violation of II. Rules of Practice [4]. These dilemmas are solvable only through long periods of code testing and debugging. In a real-world application, this period of testing can take months, sometimes years, depending on the depth of the program. Long

testing periods are set in place to ensure no deception of information is presented or collected from the program, as it would reflect poorly on Team 1 as an engineering team.

### **Conclusion**

The contents of report include the problem definition, SOTA literature review, Concept generation and selection, engineering analyses, cost analyses, and ethical standards involved in designing the Work-In. These items are essential to efficiently design a product that meets customer needs safely. The next step for the Work-In will involve contracting a team of virtual personal trainers as well as coders to refine the software the mirror would run on. Prototypes will be to find the most lightweight, ergonomic design. When ready for sale, it will be able to compete in the competitive exercise equipment market, especially at it's low price point.



### Appendix A – QFD









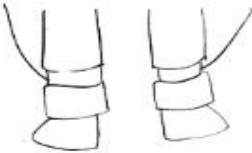
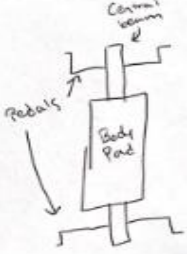
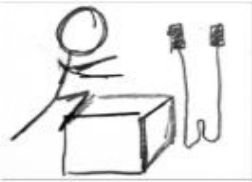

System QFD		Project: <b>Work-In</b>	
		Date: <b>2020.08.30</b>	
		Input areas are in yellow	
1	Weight		
2	Length	1	
3	Width	1	3
4	Height	1	3
5	Visual Stimulation (LED Screen)	9	1
6	Electromechanical	1	1

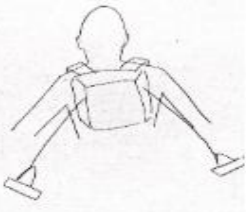
		Technical Requirements					Customer Opinion Survey					
Customer Needs	Customer Weights (1-5)	Weight	Length	Width	Height	Visual Stimulation (LED Screen)	Electromechanical	1	2	3	4	5
								1	2	3	4	5
								<i>Poor</i>		<i>Acceptable</i>		<i>Excellent</i>
1	Volume	4	1	9	9	9	1	AC		B		
2	All ages	3	3				1			ABC		
3	Motivation	3	3				9	A		B	C	
4	Cardio Workout	5					3	A		B	C	
5	Strength Workout	5					3	B		C	A	
6	Fail-Safe Feature	5								AC		B
<b>Technical Requirement Units</b>			lbs	m	m	m	N/A	N/A				
<b>Technical Requirement Targets</b>			15	1	1	1	N/A	N/A				
<b>Absolute Technical Importance</b>			22	36	36	36	64	135				
<b>Relative Technical Importance</b>			1	3	3	3	6	3				

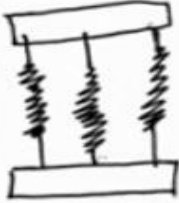
**Figure A.1 - QFD**

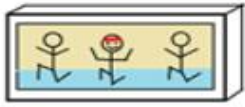
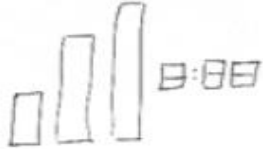
## Appendix B – Morph Matrix

Sub- functions	Concept Variants			
Provide Cardio Training	 Leg resistance straps	 Resistance pedals	 Box jump or jump rope	 On screen trainer to utilize In-Place exercises
Provide Strength Training	 Weighted backpack	 Weighted gloves	 Water Weights	 Graduated Spring Resistance system
Motivate the User	 App/Smartwatch	 Digital Mirror and motion tracking wristbands	 Motivational video screen	 Goal Tracker and Timer
Utilize Safety System To Protect User	 Chair support	 Stability in foldable chair	 Encase moving parts and sheath bands	 Seahorse tail bio-inspired design

**Figure B.1 – Morph Matrix**

Appendix C – Concepts

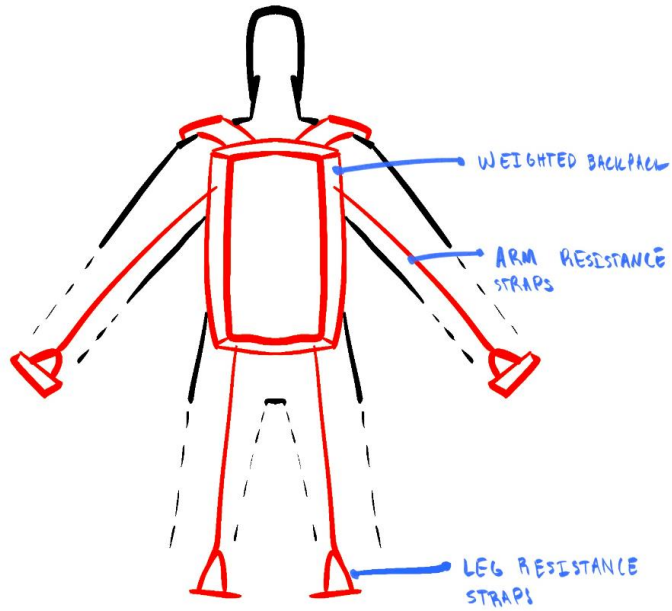

Figure C.1 – Concept 1: Jacked Pack

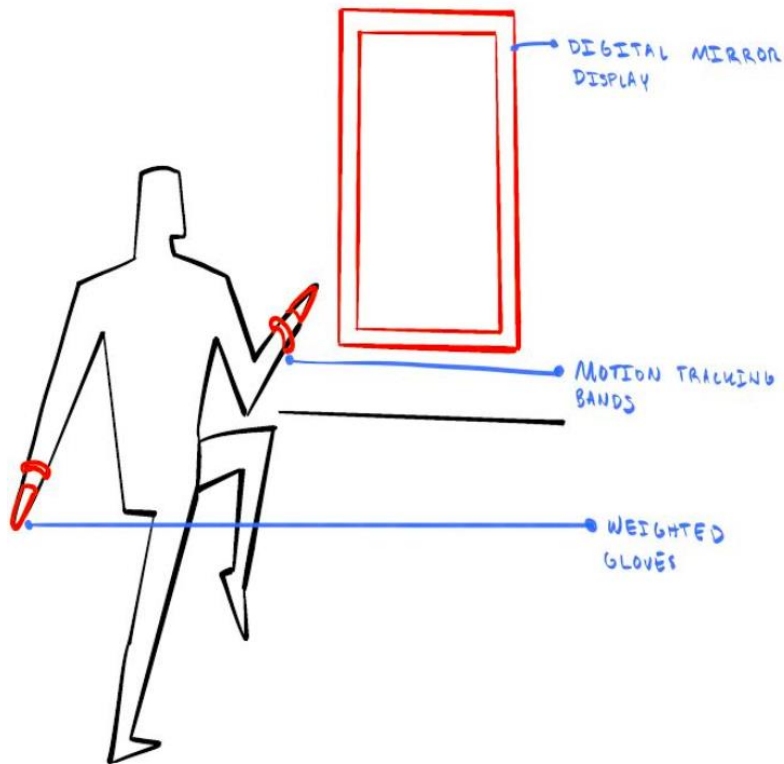
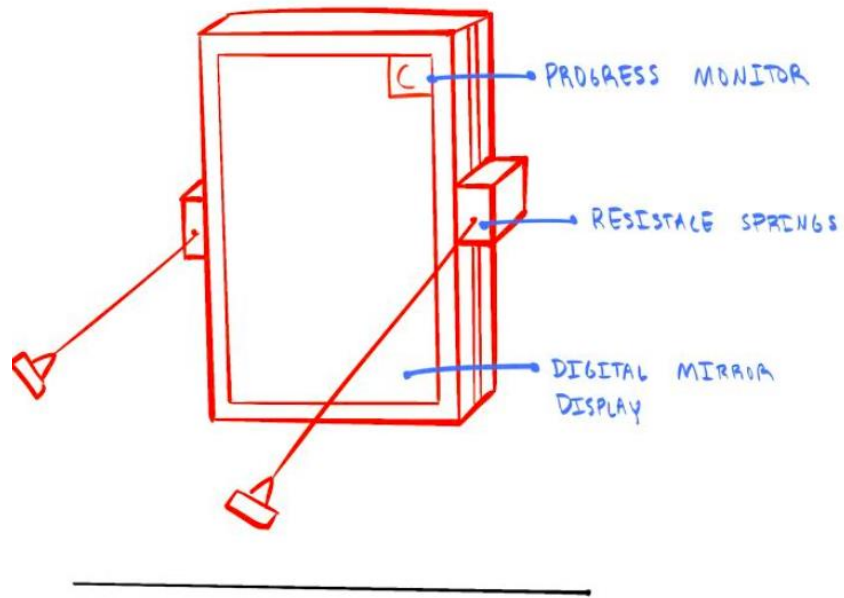
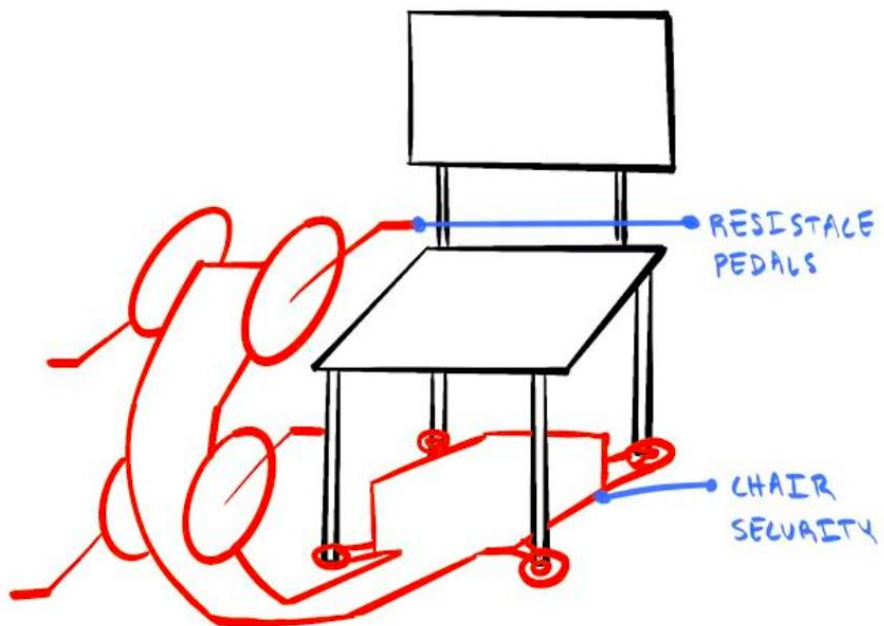

Figure C.2 – Concept 2: Body Pal



**Figure C.3 – Concept 3: Wall-n-Work**



**Figure C.4 – Concept 4: Dual Spin**

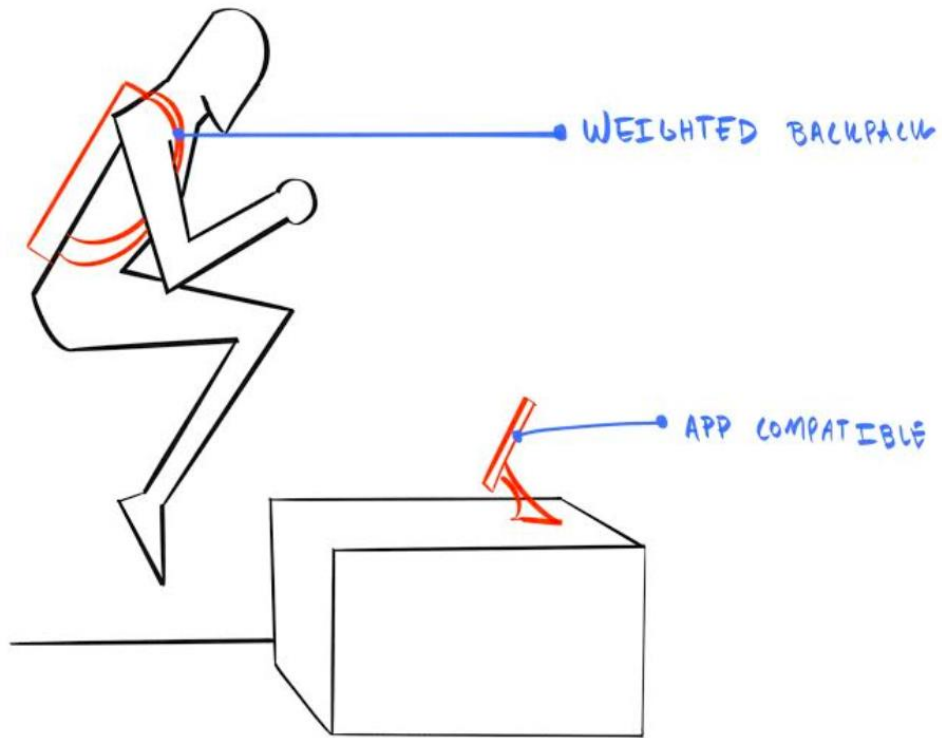

Figure C.5 – Concept 5: Box Jumper

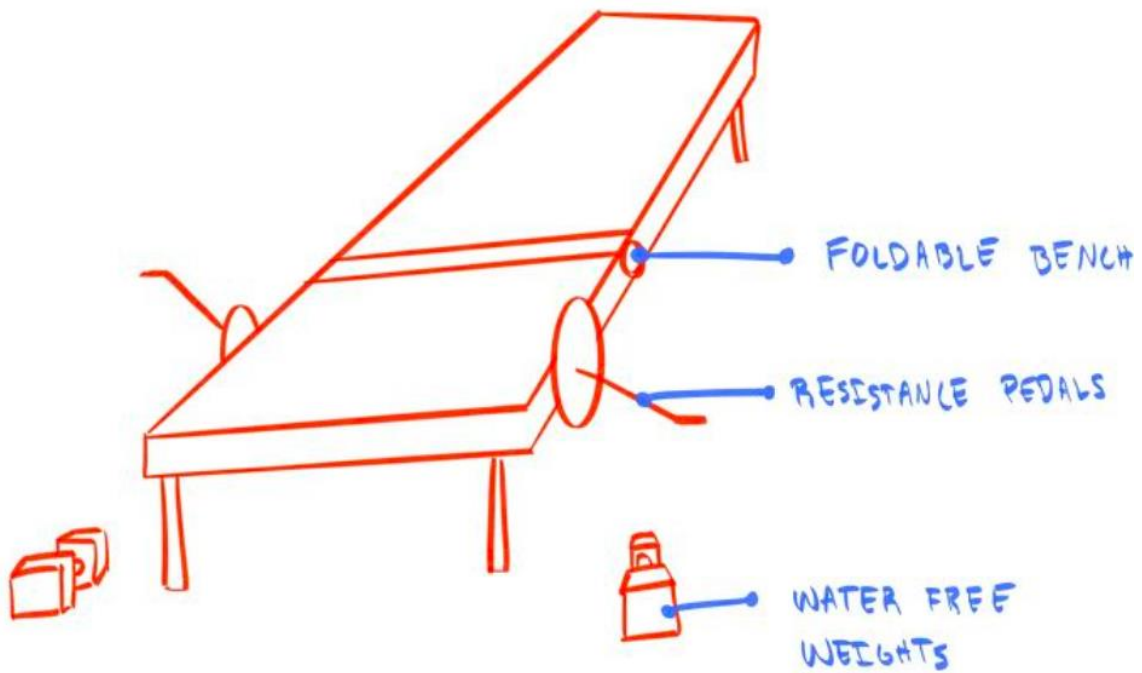

Figure C.6 – Concept 6: Water Bench

# Appendix D – Pugh Chart

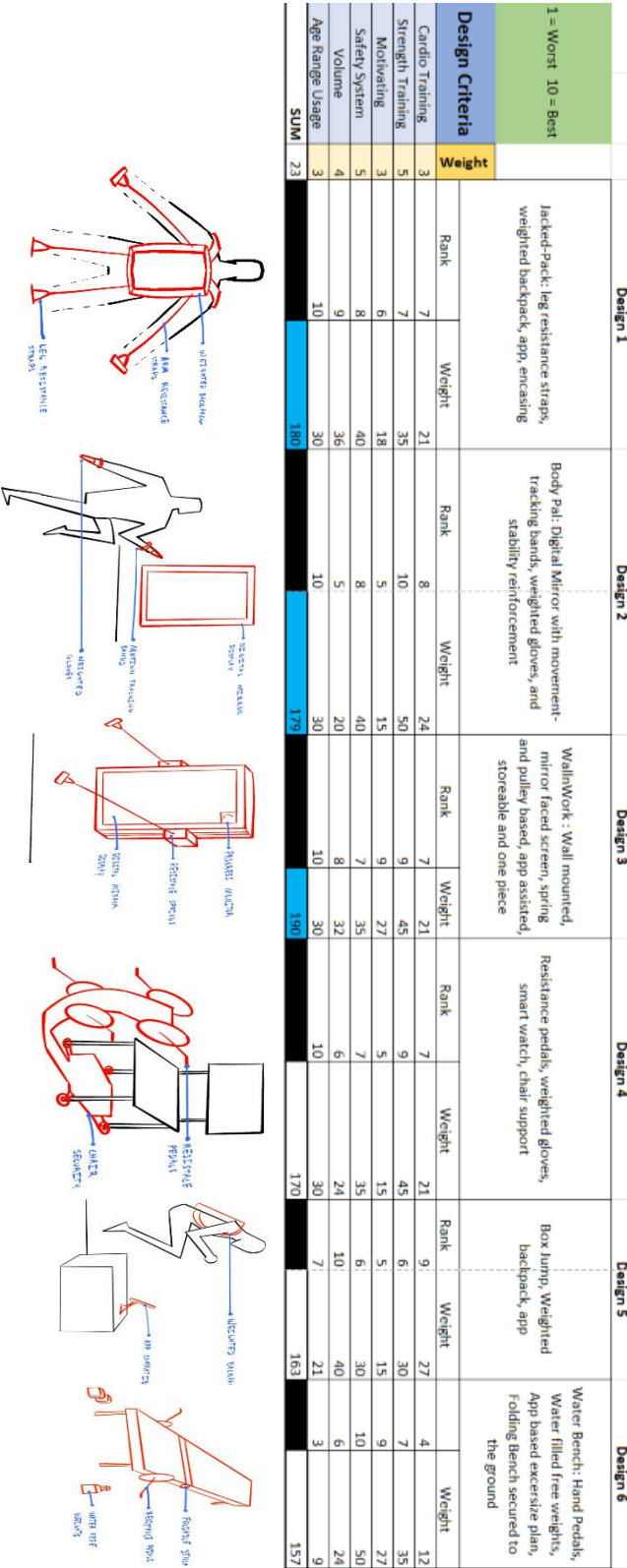
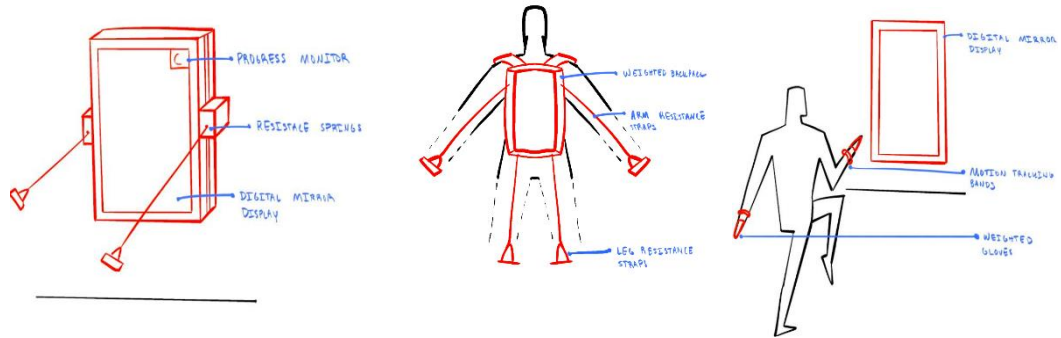

Figure D.1 – Pugh Chart

## Appendix E – Decision Matrix

1 = Worst 10 = Best	WallnWork			Jacked-Pack		Body Pal	
	Weight	Score	Weighted Score	Score	Weighted Score	Score	Weighted Score
Decrease weight	0.06567	8	0.52536	3	0.19701	7	0.45969
Decrease body length	0.1074	4	0.4296	9	0.9666	6	0.6444
Decrease body width	0.1074	9	0.9666	8	0.8592	9	0.9666
Decrease body height	0.1074	6	0.6444	8	0.8592	9	0.9666
Increase motivational stimulation	0.2089	10	2.089	3	0.6267	10	2.089
Electromechanical	0.403	10	4.03	7	2.821	10	4.03
<b>SUM</b>	<b>1.00</b>		<b>8.68496</b>		<b>6.32971</b>		<b>9.15629</b>



**Figure E.1 – Decision Matrix**

## Appendix F – Programming

```
332 class Bobby(tk.Frame):
333
334     def __init__(self, parent, controller):
335         tk.Frame.__init__(self, parent)
336         label = tk.Label(self, text="Bobby, why haven't you worked out in " + str(
337             bobby) + " days?!?!?!?!?\n\nCHOOSE WORKOUT", font=LARGE_FONT)
338         label.pack(pady=10, padx=10)
339
340         button1 = tk.Button(self, text="Select workout",
341                             command=lambda: controller.show_frame(ConnectBands))
342         button1.pack()
343
344
345 class Emily(tk.Frame):
346
347     def __init__(self, parent, controller):
348         tk.Frame.__init__(self, parent)
349         label = tk.Label(self, text="Emily, why haven't you worked out in " + str(
350             emily) + " days?!?!?!?!?\n\nCHOOSE WORKOUT", font=LARGE_FONT)
351         label.pack(pady=10, padx=10)
352
353         button1 = tk.Button(self, text="Select workout",
354                             command=lambda: controller.show_frame(ConnectBands))
355         button1.pack()
356
357
358 app = SeaofBTCapp()
```

Figure F.1 – Partial Python Code



## Appendix G – Fastener Tables

Table G.1 : Fastener Table [12]

Nominal Major Diameter $d$ mm	Coarse-Pitch Series			Fine-Pitch Series		
	Pitch $p$ mm	Tensile-Stress Area $A_s$ mm <sup>2</sup>	Minor-Diameter Area $A_n$ mm <sup>2</sup>	Pitch $p$ mm	Tensile-Stress Area $A_s$ mm <sup>2</sup>	Minor-Diameter Area $A_n$ mm <sup>2</sup>
1.6	0.35	1.27	1.07			
2	0.40	2.07	1.79			
2.5	0.45	3.39	2.98			
3	0.5	5.03	4.47			
3.5	0.6	6.78	6.00			
4	0.7	8.78	7.75			
5	0.8	14.2	12.7			
6	1	20.1	17.9			
8	1.25	36.6	32.8	1	39.2	36.0
10	1.5	58.0	52.3	1.25	61.2	56.3
12	1.75	84.3	76.3	1.25	92.1	86.0
14	2	115	104	1.5	125	116
16	2	157	144	1.5	167	157
20	2.5	245	225	1.5	272	259
24	3	353	324	2	384	365
30	3.5	561	519	2	621	596
36	4	817	759	2	915	884
42	4.5	1120	1050	2	1260	1230
48	5	1470	1380	2	1670	1630
56	5.5	2030	1910	2	2300	2250
64	6	2680	2520	2	3030	2980
72	6	3460	3280	2	3860	3800
80	6	4340	4140	1.5	4850	4800
90	6	5590	5360	2	6100	6020
100	6	6990	6740	2	7560	7470
110				2	9180	9080

\*The equations and data used to develop this table have been obtained from ANSI B1.1-1974 and B18.3.1-1978. The minor diameter was found from the equation  $d_r = d - 1.226\ 869p$ , and the pitch diameter from  $d_p = d - 0.649\ 519p$ . The mean of the pitch diameter and the minor diameter was used to compute the tensile-stress area.

Table G.2 : Fastener Table Continued [12]

Size Designation	Coarse Series—UNC				Fine Series—UNF		
	Nominal Major Diameter in	Threads per Inch N	Tensile-Stress Area $A_s$ in <sup>2</sup>	Minor-Diameter Area $A_n$ in <sup>2</sup>	Threads per Inch N	Tensile-Stress Area $A_s$ in <sup>2</sup>	Minor-Diameter Area $A_n$ in <sup>2</sup>
0	0.0600				80	0.001 80	0.001 51
1	0.0730	64	0.002 63	0.002 18	72	0.002 78	0.002 37
2	0.0860	56	0.003 70	0.003 10	64	0.003 94	0.003 39
3	0.0990	48	0.004 87	0.004 06	56	0.005 23	0.004 51
4	0.1120	40	0.006 04	0.004 96	48	0.006 61	0.005 66
5	0.1250	40	0.007 96	0.006 72	44	0.008 80	0.007 16
6	0.1380	32	0.009 09	0.007 45	40	0.010 15	0.008 74
8	0.1640	32	0.014 0	0.011 96	36	0.014 74	0.012 85
10	0.1900	24	0.017 5	0.014 50	32	0.020 0	0.017 5
12	0.2160	24	0.024 2	0.020 6	28	0.025 8	0.022 6
$\frac{1}{4}$	0.2500	20	0.031 8	0.026 9	28	0.036 4	0.032 6
$\frac{5}{16}$	0.3125	18	0.052 4	0.045 4	24	0.058 0	0.052 4
$\frac{3}{8}$	0.3750	16	0.077 5	0.067 8	24	0.087 8	0.080 9
$\frac{7}{16}$	0.4375	14	0.106 3	0.093 3	20	0.118 7	0.109 0
$\frac{1}{2}$	0.5000	13	0.141 9	0.125 7	20	0.159 9	0.148 6
$\frac{9}{16}$	0.5625	12	0.182	0.162	18	0.203	0.189
$\frac{5}{8}$	0.6250	11	0.226	0.202	18	0.256	0.240
$\frac{3}{4}$	0.7500	10	0.334	0.302	16	0.373	0.351
$\frac{7}{8}$	0.8750	9	0.462	0.419	14	0.509	0.480
1	1.0000	8	0.606	0.551	12	0.663	0.625
$1\frac{1}{2}$	1.2500	7	0.969	0.890	12	1.073	1.024
$1\frac{1}{2}$	1.5000	6	1.405	1.294	12	1.581	1.521

\*This table was compiled from ANSI B1.1-1974. The minor diameter was found from the equation  $d_r = d - 1.299\ 038p$ , and the pitch diameter from  $d_p = d - 0.649\ 519p$ . The mean of the pitch diameter and the minor diameter was used to compute the tensile-stress area.

Table G.3 : Fastener Table Strengths [12]

SAE Grade No.	Size Range Inclusive, in	Minimum Proof Strength,* kpsi	Minimum Tensile Strength,* kpsi	Minimum Yield Strength,* kpsi	Material	Head Marking
1	$\frac{1}{4}$ – $1\frac{1}{2}$	33	60	36	Low or medium carbon	
2	$\frac{1}{4}$ – $1\frac{1}{2}$	55	74	57	Low or medium carbon	
		33	60	36		
4	$\frac{1}{4}$ – $1\frac{1}{2}$	65	115	100	Medium carbon, cold-drawn	
5	$\frac{1}{4}$ – $1\frac{1}{2}$	85	120	92	Medium carbon, Q&T	
		74	105	81		
5.2	$\frac{1}{4}$ –1	85	120	92	Low-carbon martensite, Q&T	
7	$\frac{1}{4}$ – $1\frac{1}{2}$	105	133	115	Medium-carbon alloy, Q&T	
8	$\frac{1}{4}$ – $1\frac{1}{2}$	120	150	130	Medium-carbon alloy, Q&T	
8.2	$\frac{1}{4}$ –1	120	150	130	Low-carbon martensite, Q&T	

\*Minimum strengths are strengths exceeded by 99 percent of fasteners.

## Appendix H – Time Value of Money

Table H.1: Time Value of Money

Cost Items	Reasoning	Total over 2 Years
Salaries	75k per Year	600,000
Rent	2k per Month	48,000
Utilities	400 per Month	9,600
Computer Hardware	2000 per Person	8,000
Contract Work	App Design	10,000
Materials	Prototyping	5,000
Manufacturing	Prototyping	25,000
15% Error	15% for Safety	705600 x 1.15
	Total	811440

$$FV = PV * \left[1 + \left(\frac{i}{n}\right)\right]^{x*t}$$

***In Equation 14:***

***FV = Future Value of money***

***PV = Present Value of money***

***i = interest rate***

***n = number of compounding periods per year***

***t = number of years***

## References

- [1] <https://www.onepeloton.com/shop/bike>
- [2] [https://www.mirror.co/shop/mirror?utm\\_source=google\\_ads&utm\\_medium=google\\_shopping&utm\\_campaign=mirror\\_shopping](https://www.mirror.co/shop/mirror?utm_source=google_ads&utm_medium=google_shopping&utm_campaign=mirror_shopping)
- [3] <https://www.bowflex.com/home-gyms/xtreme-se/100026.html>
- [4] "Code of Ethics," Code of Ethics | National Society of Professional Engineers. [Online]. Available: <https://www.nspe.org/resources/ethics/code-ethics>. [Accessed: 2-Nov-2020].
- [5] A. Berger, "Oscillatory Blood Pressure Monitoring Devices," *BMJ : British Medical Journal*, 20-Oct-2001. [Online]. Available: <https://www.ncbi.nlm.nih.gov/pmc/articles/PMC1121444/>. [Accessed: 12-Oct-2020].
- [6] A. Haniyamballi, "Do rubber bands follow Hooke's law?," *A Differential Mind*, 14-Nov-2017. [Online]. Available: <https://gh-adithya.blogspot.com/2017/11/do-rubber-bands-follow-hookeslaw.html>. [Accessed: 12-Oct-2020].
- [7] "Blood pressure chart: What your reading means," *Mayo Clinic*, 09-Jan-2019. [Online]. Available: <https://www.mayoclinic.org/diseases-conditions/high-blood-pressure/in-depth/blood-pressure/art20050982>. [Accessed: 12-Oct-2020].
- [8] "Energy Use," *MAP Dashboard*, 26-May-2020. [Online]. Available: <https://mapazdashboard.arizona.edu/infrastructure/energy-use>. [Accessed: 26-Oct-2020].
- [9] "How Much Electricity Do My Home Appliances Use: IGS," *IGS*. [Online]. Available: <https://www.igs.com/energy-resource-center/energy-101/how-much-electricity-do-myhome-appliances-use>. [Accessed: 26-Oct-2020].
- [10] "Compendium of Physical Activities." [Online] Available: <https://sites.google.com/site/compendiumofphysicalactivities/home>. [Accessed: 25-Sep-2020].
- [11] J. Roland, "What Are METs, and How Are They Calculated?," 22-Oct-2019. [Online]. Available: <https://www.healthline.com/health/what-are-mets>. [Accessed: 28-Sep-2020].
- [12] R. G. Budynas, J. K. Nisbett, and J. E. Shigley, "Ch 8," in *Shigley's mechanical engineering design*, New York: McGraw-Hill, 2016.
- [13] Berchtold, Cornelius, Castano, Dorantes, HW8 Cost Analysis Submission